

PRODUCT:

QUANTITY:

ITEM #:

## Designed Smart

### Developed for High Performance!

- X\*PERT™ SERIES Holding Drawers are designed to hold everything from crispy foods to moist foods at required UL Sanitation temperatures.
- Temperature in each drawer is capable of reaching up to 200°.
- New digital solid-stat control systems provide a more consistent flow of energy (Tighter cycle swings), resulting in rapid start up and recovery times.
- Perimeter heating elements distribute heat evenly through the drawer area, promoting consistent food temperatures throughout the food pan while avoiding scalding due to warmer "hot spots".
- Adjustable pan supports accommodate various pan sizes.

### Energy Efficient!

- The complete drawer compartment is protected with one inch fiberglass insulation, including the drawer front panels. Insulation focuses heat into the food and keeps exterior panels "cool to the touch".

### Easy to Maintain and Service!

- Holding pan lifts directly out of drawer, allowing for quick cleaning and maintenance.
- Side control panel with LED read-outs make it simple for employees to set correct temperatures and to monitor holding conditions.

## Built Solid

### Built to Last

- Frame, interior and exterior construction is made with stainless steel.
- Drawers are constructed with 11 gauge stainless steel drawer slides that ride on two reinforced 14 gauge stainless steel slide brackets. (Will not bend or warp drawer tracking system.)
- Each drawer slide rides on 4 self lubricated, stainless steel rollers that are secured to the interior walls with a reinforced bolt system.
- X\*PERT™ SERIES drawer slides feature a unique "jam-free" side roller, a design that facilitates the smoothest closing action in the industry from any angle in which the operator pushes the drawer.

## Reliability backed by APW Wyott's Warranty

All APW Wyott holding drawers are backed by a 1-year parts and labor warranty, including on-site service calls within 50 miles of authorized service technicians.

Certified by the following agencies:



Model: HDXi-1 Countertop Holding Drawer

## APW Wyott Design Features

- Heavy-duty stainless steel construction for the frame, exterior and interior.
- Fully insulated compartments with 1" thick fiberglass sheets on top, sides, and drawer fronts.
- 11 gauge stainless steel drawer slides with reinforced 14 gauge slide brackets.
- Side "Jam-free" roller design on the drawer slide.
- Each drawer individually controlled by a LED controller, with temperature ranges of 80°-220°F (27°-93°C).
- Adjustable vent controls on each drawer.
- Each drawer has removable 12"x20"x6" deep stainless steel pan.
- Adjustable pan supports accommodate various pan sizes.

## Options

- Perforated well-pan bottom (14900)
- 3" or 5" swivel casters
- 6" stainless steel legs (standard on HDXi-4)
- Color Drawer Fronts (call factory for available colors and cost)
- Spillage pan (33018)

## Consultant Specifications

The Holding Drawer Warmers shall be a APW Wyott Model ...., as manufactured by the APW Wyott, Dallas, TX, U.S.A. The unit shall have ....drawer(s) and be rated at ....watts, ....amps. Freestanding model shall be equipped with a cord and plug. The Drawer Warmer shall have a stainless steel exterior, interior, drawer slides, and assembly. Drawer rollers shall be self lubricated, stainless steel. The drawer slide shall have the "jam-free" side roller system. The unit shall be insulated in the top, sides and drawer fronts of each compartment and have individual power switch, thermostat and temperature monitor for each drawer.

See reverse side for product specification

PRODUCT:

QUANTITY:

ITEM #:

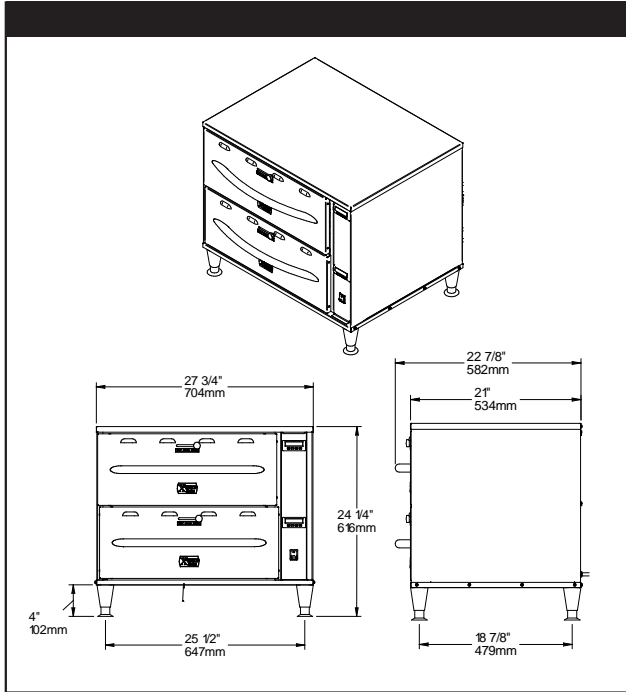

## PRODUCT SPECIFICATIONS

### Construction:

X\*PERT Holding drawer exterior and interior base construction is made of 20-gauge Stainless Steel. Drawer slides are made with 11-gauge Stainless Steel. 1" insulation on top and side panels. 4" Adjustable legs are shipped with 1.2 and 3 drawer versions. 4 drawer versions are shipped with 6" adjustable legs.

### Electrical Information:

Each unit is equipped with a 6", three wire, grounded power cord that terminates with a 90° three pronged male plug. The 1, 2, and 3 drawer 120V units use a NEMA 5-15P plug. The 4 drawer 120V units use a NEMA 5-20 plug. The 208/240V unit uses a NEMA 6-15P plug. Plugs exit out of the right rear of the equipment.

### Shipping:

Freight Class: 92 ½  
FOB Arizona, 85621

Standard Holding Drawers			
	Electric	Dimensions	Shipping Wt.
HDXi-1	120V, 450W, 3.8Amps	14-15/16"Hx27-3/4"Wx21"D* (379mm x 704mm x 534mm)	120 lbs (56kg)
	208V, 450W, 2.1Amps		
	240V, 450W, 1.8Amps		
HDXi-2	120V, 900W, 7.5Amps	24-1/4"Hx27-3/4"Wx21"D* (616mm x 704mm x 534mm)	170 lbs (77 kg)
	208V, 900W, 4.3Amps		
	240V, 900W, 3.7Amps		
HDXi-3	120V, 1350W, 11.3Amps	33-11/16"Hx27-3/4"Wx21"D* (856mm x 704mm x 534mm)	220lbs (100kg)
	208V, 1350W, 6.5Amps		
	240V, 1350W, 5.6Amps		
HDXi-4	120V, 1800W, 15Amps	43 1/16"Hx27-3/4"Wx21"D* (x 704mm x 534mm)	270lbs
	208V, 1800W, 8.7Amps		
	240V, 1800W, 7.5Amps		

\*Includes legs without handle

\*APW Wyott Reserves the right to modify specifications or discontinue models without incurring obligation.