

PRODUCT:

QUANTITY:

ITEM:

Designed Smart

- Mobile, Cantilever-Type, Self-Leveling dispenser that is easily field adjustable for dispensing racks of cups with Adjustube® dispensers for dispensing saucers.
- CTRS Mobile Cup and Saucer Dispensers are excellent for use in serving lines, tray makeup lines, or at hot beverage service points. They are open on three sides for easy access.
- Lift-out panel for easy access to dispensing mechanism.
- Full base for sanitary protection and empty rack storage
- Convenient push handle.

APW Wyott Design Features

- Stainless steel construction with standard protective corner bumper.
- Open sided construction for versatility
- 4" polyurethane casters. Rear caster brakes
- Dependable and adjustable extension spring dispensing mechanism.

Reliability backed by APW Wyott's Warranty

All APW Wyott Lowerators are backed by a 1-year limited warranty and a 1-year on-site labor warrant. *

•Certified by the following agencies:



Model: Mobile Cup and Saucer Lowerator®

OPTIONS

- 5" polyurethane casters, two with brakes (installation not included) (add -5P to model number)
- Perimeter (add-PB to model number)

See reverse side for product specifications.

PRODUCT:

QUANTITY:

ITEM:

PRODUCT SPECIFICATION

Construction:

All stainless steel exterior and base, saucer lowerator tube made of mirror polished stainless steel, coated stainless steel springs. 4" polyurethane casters and rubber protective bumpers.

Dispensing System:

- Cup Rack Dispenser:** Easily field adjustable to a wide load range. By connecting the self-contained extension springs, the load rate can be increased in increments of 1 pound per inch. Stainless steel carrier cannot bind or tip.
- Saucer Dispenser:** All models have Adjustubes® with 25 1/2" vertical storage. Tubes have field adjustable spring rate (no tools needed). By connecting the self-contained extension springs, the load rate can be increased to increments of 2.5 oz./in. or 4 oz./in. Each tube also has a storage bank for springs when not in use.

Capacity:

To 125 trays, 14 dozen glasses, 12 dozen saucers. Vertical storage: 27 1/8" (23" travel and 4 1/8" to top of upright).

FOB: Cheyenne, WY 82007

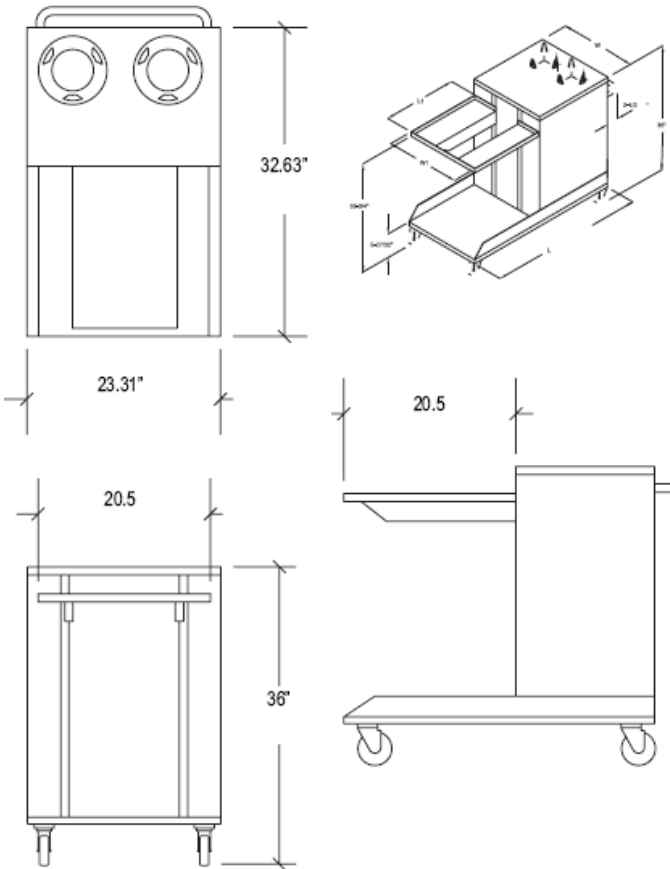

Model Number	Platform Dimensions		Overall Dimensions		Shipping Weight	Saucer Size
	W1	L1	W	L		
CTRS-2020-5	20 1/2"	20 1/2"	23 7/16"	39 11/16"	199 lbs	Up to 5"
CTRS-2020-6	20 1/2"	20 1/2"	23 7/16"	39 11/16"	199 lbs	5 1/8 to 5 3/4"
CRTS-2020-6.5	20 1/2"	20 1/2"	23 7/16"	39 11/16"	199 lbs	5 7/8 to 6 1/2"

Overall dimensions include 2 1/2" for corner bumpers.

*APW Wyott reserves the right to modify specifications or discontinue models without incurring obligation.